

Instruction Manual  
Cool SmartLift series



Date: 05-04-2017

Version: 0.5

LoadLok® International B.V.

Oudewei 4

4004 LS TIEL

Nederland

T +31 (0)344-670 960

F +31 (0)344-722 960

## Document history

Version	Status	Date	Author	Remarks
0.1	Concept	13 Jan 2017		
0.5	Review	05 Apr 2017		

**Contents**

- 1 Introduction ..... 4
  - 1.1 Preface ..... 4
  - 1.2 Common information ..... 4
  - 1.3 Notes to the operator ..... 4
  - 1.4 Reading instructions ..... 4
  - 1.5 List with abbreviations ..... 5
- 2 Safety ..... 6
  - 2.1 Signs on the product ..... 6
  - 2.2 Signs in the manual ..... 6
- 3 Mounting the IsoLok Track ..... 7
  - 3.1 Parts needed ..... 7
    - 3.1.1 Mandatory parts ..... 7
    - 3.1.2 Optional parts ..... 8
    - 3.1.3 Consumables ..... 10
    - 3.1.4 Parts to be supplied by yourself ..... 11
  - 3.2 Tools needed ..... 12
- 4 Mounting the track ..... 14
- 5 Installation of the Cool SmartLift series wall in the vehicle ..... 19
- 6 Check the functionality of Cool SmartLift series wall ..... 24
  - 6.1 Adjust spring tension ..... 24
  - 6.2 Check the break functionality ..... 26
  - 6.3 Connecting the built-in fan ..... 28
    - 6.3.1 Without the power supply kit ..... 28
    - 6.3.2 With the power supply kit ..... 29
  - 6.4 Double Decking systems and Cool SmartLift series wall ..... 31
- 7 Maintenance ..... 33
- 8 Document information ..... 34

## 1 INTRODUCTION

### 1.1 PREFACE

This operating manual is an essential aid for the correct and safe use of the insulation partition walls.

This manual contains important information for reliable, proper and efficient use of the insulating partitions. Adherence to the manual helps to avoid dangers, reduce repair costs and downtime and increase the reliability and the lifetime of insulating walls.

The instructions must be available to the operating personnel at all times. Any person who is authorized to use the insulating walls reads the operating instructions before use and then applies them accordingly.

### 1.2 COMMON INFORMATION

Do not expose the Cool SmartLift series wall to outside weather conditions, extreme temperatures and direct sunlight.

Any change to the product makes the CE marking invalid. Please contact the manufacturer, if a modification of the product is necessary.

Loadlok reserves the right, if not being met to the requirements, to withdraw the guarantee of their product partially or entirely.

At the end of the lifecycle:

The end user can deliver the multi temp product to Loadlok. Loadlok provides environmentally sound disposal of their product and recycles parts if these are fit for reuse.

### 1.3 NOTES TO THE OPERATOR

This manual is an essential part of the insulating walls. The customer shall ensure that the operator adheres these instructions.

Note that in addition to the instructions, the laws of the country of the place of use are applicable and approved rules for accident prevention alongside with approved technical regulations for safe and professional work shall apply.

Any change to the product makes the CE marking invalid. Please contact the manufacturer, if a modification of the product is necessary.

### 1.4 READING INSTRUCTIONS



**WARNING:**

This is a warning of a potentially hazardous situation, resulting moderate or minor injury and / or property damage if the appropriate instruction is not followed exactly.



**ATTENTION:**

This is a reference to useful information for the safe and effective use.

Orientation

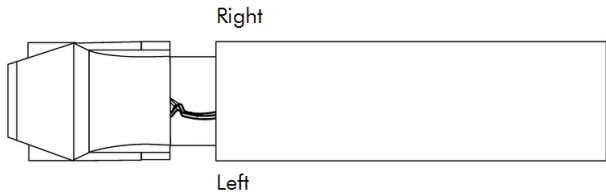
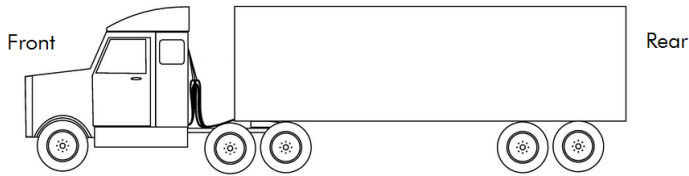





**1.5 LIST WITH ABBREVIATIONS**



- 3060 J-formed rail to guide the wall into the trailer.
- 3062 J-formed rail with locking holes to guide the wall into the trailer.

## 2 SAFETY

### 2.1 SIGNS ON THE PRODUCT

 <p><b>ID. nr: TW60-0203</b></p> <p>MANUFACTURED BY:  DISTRIBUTED BY: </p>	<p>Type designation sign</p> <p>Common information of the Cool SmartLift series wall</p>
 <p>Dient <b>NICHT</b> zur Ladungssicherung! Do <b>NOT</b> use for load securing!</p>	<p>Warning sign</p> <p>Do not use the Cool SmartLift series wall as a load securing device!</p>
<p><b>WARNING</b> COIL SPRING UNDER HIGH TENSION <small>Untrained personnel must not attempt to open or tamper with this mechanism, injury could result.</small></p> <p><b>ACHTUNG</b> LEBENSGEFAHR! <small>Nur durch Fachpersonal zu öffnen!</small></p> <p><b>PAS OP</b> VEER ONDER SPANNING! <small>Alleen door vakkundig personeel te openen!</small></p>	<p>Warning sign</p> <p>The balancer is a spring activated device.</p>



### 2.2 SIGNS IN THE MANUAL

	<p>WARNING:</p> <p>This is a warning of a risk of danger, with the possible consequence serious injury or death if the designated instruction is not exactly is followed.</p>
	<p>WARNING:</p> <p>This is a warning of a potentially hazardous situation, resulting moderate or minor injury and / or property damage if the appropriate instruction is not followed exactly.</p>
	<p>ATTENTION:</p> <p>This is a reference to useful information for the safe and effective use.</p>

### 3 MOUNTING THE ISOLOK TRACK

#### 3.1 PARTS NEEDED

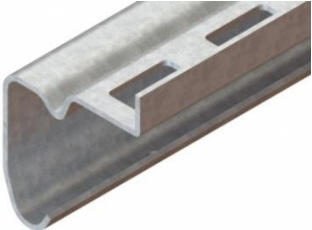
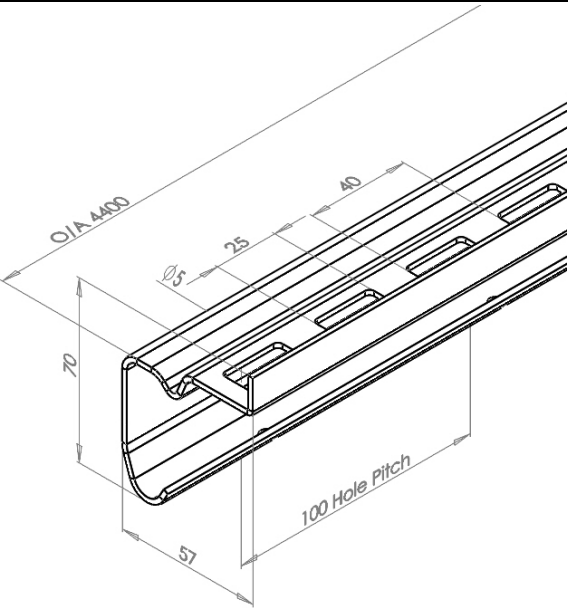

##### 3.1.1 Mandatory parts

Material	Measurements	Article number / Description												
<p>Frigo58-track</p>   <p>Alternative article numbers with descriptions:</p> <table border="0"> <tr> <td>14001345</td> <td>10009470</td> </tr> <tr> <td>3062 PRE GALV 4400 IsoLok Track</td> <td>3062 SS304 3200 CS IsoLok Track</td> </tr> <tr> <td>14001340</td> <td>14001344</td> </tr> <tr> <td>3062 SS304 4400 IsoLok Track</td> <td>3062 SS430 3200 IsoLok Track</td> </tr> <tr> <td>14003604</td> <td>14001329</td> </tr> <tr> <td>3062 SS430 4400 IsoLok Track</td> <td>3061 PG 3200 IsoLok Track</td> </tr> </table> <p>Notes:</p>	14001345	10009470	3062 PRE GALV 4400 IsoLok Track	3062 SS304 3200 CS IsoLok Track	14001340	14001344	3062 SS304 4400 IsoLok Track	3062 SS430 3200 IsoLok Track	14003604	14001329	3062 SS430 4400 IsoLok Track	3061 PG 3200 IsoLok Track		<p>14001332 3062 SS304 3200 IsoLok Track</p>
14001345	10009470													
3062 PRE GALV 4400 IsoLok Track	3062 SS304 3200 CS IsoLok Track													
14001340	14001344													
3062 SS304 4400 IsoLok Track	3062 SS430 3200 IsoLok Track													
14003604	14001329													
3062 SS430 4400 IsoLok Track	3061 PG 3200 IsoLok Track													
<p>Rubber end stop</p>  <p>Notes: To be fitted on all ends. Is not accompanied with fasteners.</p>		<p>11060164 Rubber endstop extra hole</p>												

**3.1.2 Optional parts**

Material	Measurements	Article number / Description
<p>Steel stopper right side</p>  <p>Notes: Is delivered without fasteners</p>		<p>14003348</p> <p>Steel stopper rightside for Bulkheads</p>
<p>Steel stopper left side</p>  <p>Notes: Is delivered without fasteners</p>		<p>14003346</p> <p>Steel stopper leftside for Bulkheads</p>
<p>Roller wheels on a short axle</p>  <p>Notes:</p>		<p>12009541</p> <p>Roller wheels axle 48mm</p>
<p>Roller wheels on a long axle</p> 		<p>12009540</p> <p>Roller wheels axle 119mm MK1</p>

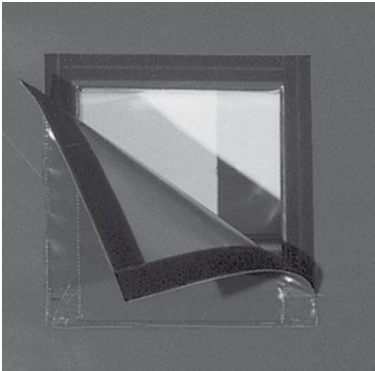
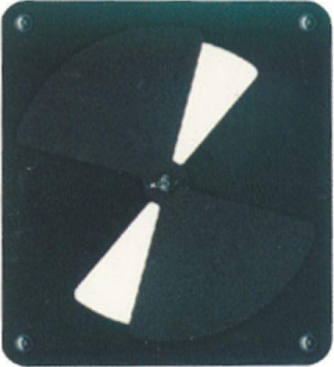

Material	Measurements	Article number / Description
Notes:		
<p>Air return vent</p> 		<p>11060262 Air return kit Cool series wall</p>
Notes: Opening closed with a tarpaulin sheet with velcro		
<p>Air return vent</p> 		<p>12010099 Butterfly air return</p>
Notes: Opening closed with a butterfly valve		
<p>Ventilator with thermostat</p> 		<p>11060320 Cool series wall80 12V Fan cable switch.</p>
Notes: Spiral cable is included		

### 3.1.3 Consumables

Material	Measurements	Article number / Description
Polar wear strip  Notes:		12009573 PVC safestrip super polar

**3.1.4 Parts to be supplied by yourself**

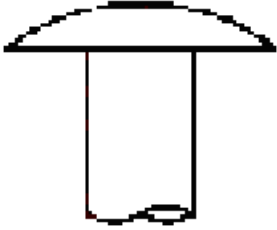
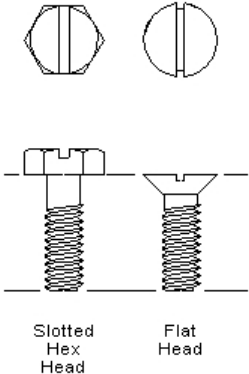
Material	Measurements	Article number / Description
<p>Rivets</p>  <p>Notes: The length of the rivet is subject to the composition of the insulation wall of the trailer.</p> <p>This article is not in the delivery program of LoadLok.</p>	<p>Max 5 mm diameter</p>	<p>N.A.</p>
<p>Screw bolt</p>  <p>Slotted Hex Head      Flat Head</p> <p>Notes: The length of the screw bolt is subject to the composition of the insulation wall of the trailer.</p> <p>Flathead optional: holes counter sunk for flush mounting. If this is a preference for mounting the IsoLok Track, the mounting holes can be made counter sunk.</p> <p>This article is not in the delivery program of LoadLok.</p>	<p>Max 5 mm diameter</p>	<p>N.A.</p>

### 3.2 TOOLS NEEDED

Blind rivet pliers



Wrench



Spirit level tool



Allen key



Measuring tape



Extended wrench  
24mm hex  
1/2 inch



Pipe wrench



Socket wrench



## 4 MOUNTING THE TRACK



**ATTENTION:**

The procedure as described here must be performed twice, once on the left hand side and once on the right hand side of the trailer.

1. Measure the effective length of track to be used.

2.

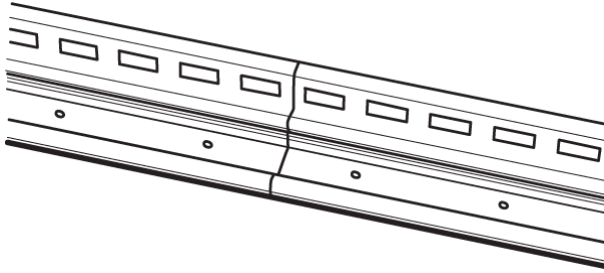

For smooth running of the balancer trolley wheels over several tracks LoadLok advises to weld the tracks in the joining point in such way the balancer or trolley wheels never can interfere with the weld.

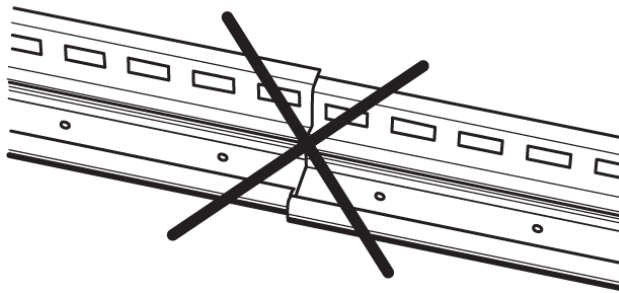

Make sure that the end edges of the rails are straight, so that the wheels of the vehicle can run continuous smoothly.

3. If the Frigo58-track is to be shortened, please leave enough material length in order to fasten the rubber end-stop with its steel cover plate.



**ATTENTION:**

Loadlok advises to use glue between the IsoLok Track and side walls which is fit for this purpose.

4.

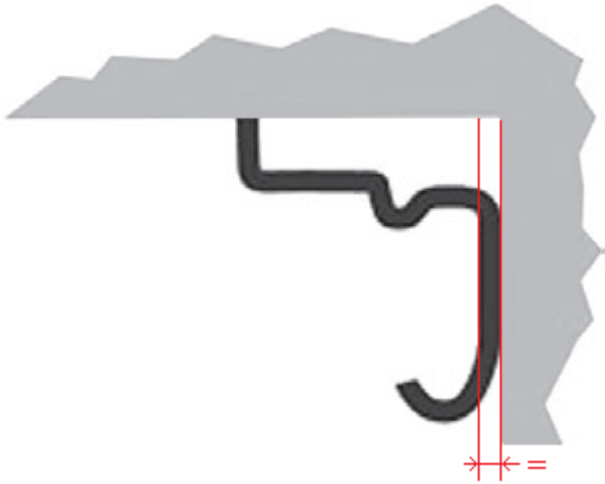

Insert the guide rails in the outer left or right side of your vehicle.  
Install the rails vertical (both to the wall and also to the ceiling).

5.

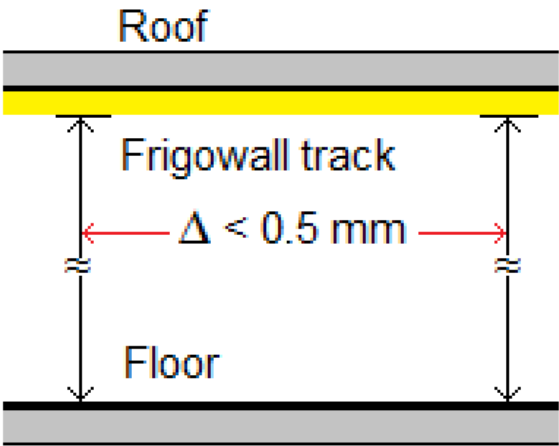

Side view

Measure the distance from the floor to the IsoLok Track on both ends of the track.  
The difference must be less than 0.5 mm as is shown in figure.

6.

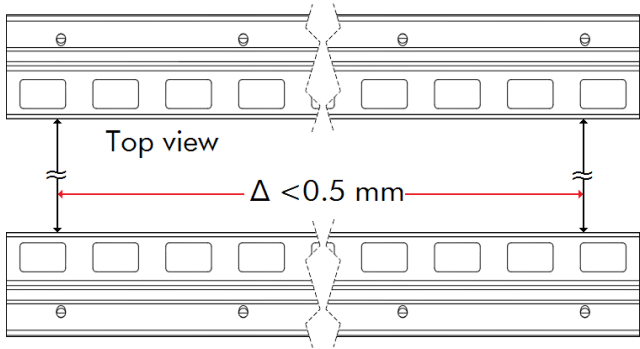

Measure the distance between the tracks in the vehicle, like is shown in the figure.  
The difference must be less than 0.5 mm.

7.

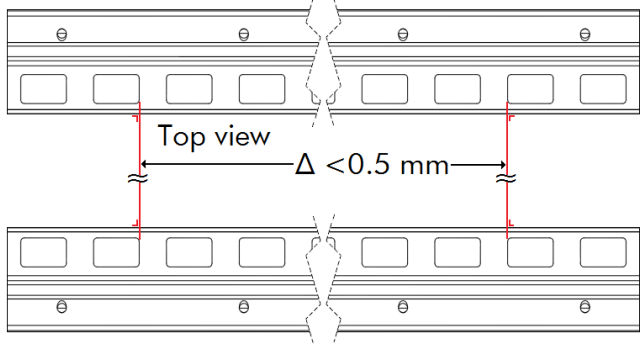

The locking holes **must** be parallel.  
The difference must be less than 0.5 mm.



ATTENTION:

Maintain the Frigo58-track on level!  
The tolerance for smooth running is  $< 0.5$  mm!

8. Use **all** mounting holes with a rivet or a screw bolt.



ATTENTION:

When using rivets:  
Please fasten the IsoLok Track at least of a length of 750 mm  
with bolts for maintenance purposes of the Frigo58 door. These  
sections must be opposite to each other!



ATTENTION:

Wait until the adhesive is fully hardened. Only then proceed  
with rolling the Cool SmartLift series wall assembly into the track.

9. In the case the trailer is reinforced in the edges with corner profiles:

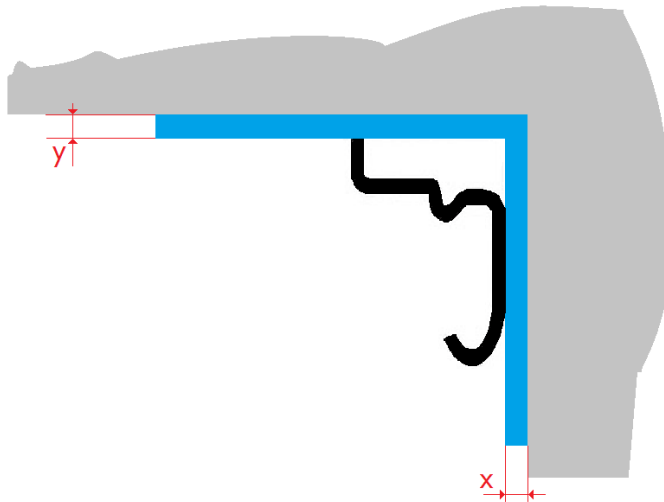

The corner profile is shown in  
blue colour.



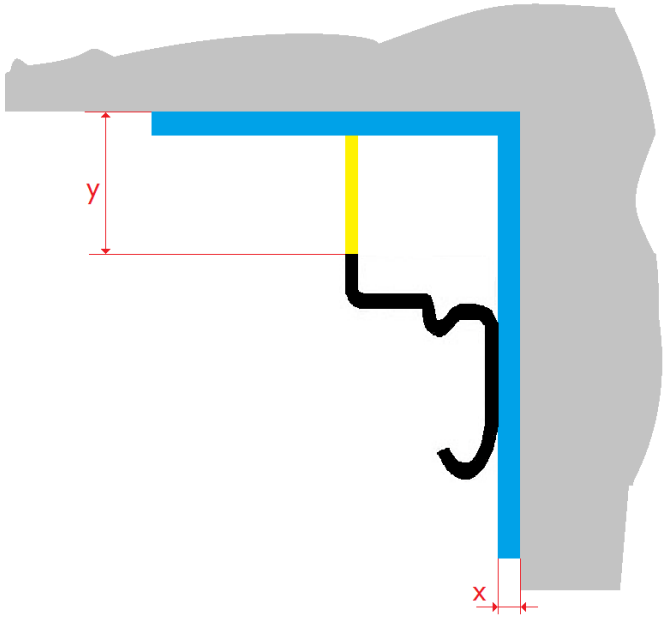

LoadLok advises to fill up the gap between the roof and the Frigo58-track. (shown in the figure in yellow)

 **ATTENTION:**  
The X and Y values are passed when ordering the Cool SmartLift series wall!

 **ATTENTION:**  
Note that the locking holes must remain free of obstacles

10. Mount the end stops at the bulkhead side of the track. (As is shown on position 11 or 12)

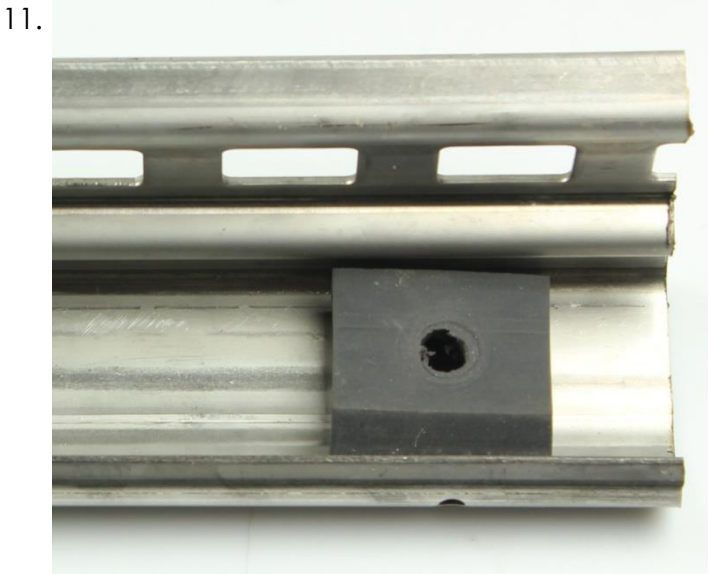

Use the drain hole to mount / attach the end stop.  
LoadLok advises to use a M5 x 30 bolt.

12.

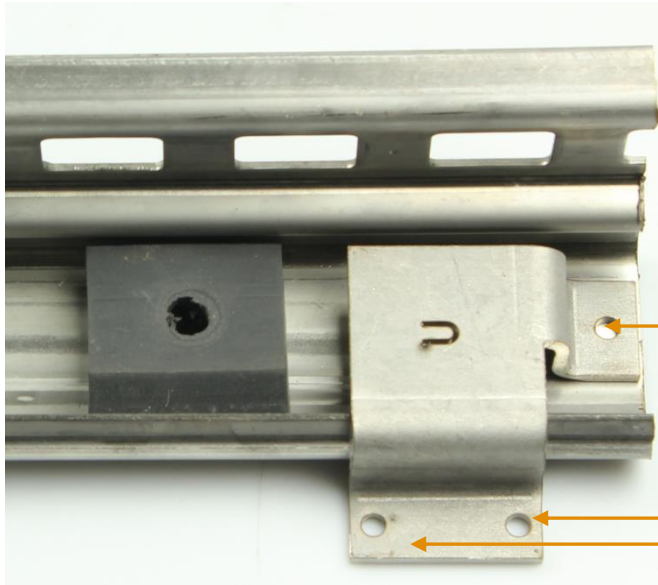



Optional mount the steel stopper as shown in the figure. The hole in the IsoLok Track must be drilled.

In total 3 holes must be drilled!

## 5 INSTALLATION OF THE COOL SMARTLIFT SERIES WALL IN THE VEHICLE

 **WARNING:**  
Ensure that the vehicle is positioned on a horizontal plane before continuing with the installation!

 **WARNING:**  
Severe injuries are possible due to the falling wall.  
Use a lashing strap to secure the wall on the forks of the forklift to avoid falling.

 **ATTENTION:**  
Cover the lifting equipment as a precaution with soft material, in order to prevent damaging the Cool SmartLift series wall.

1. Secure the Cool SmartLift series wall with a lashing strap on the forks of the forklift to avoid falling.



Lift the complete Cool SmartLift series wall with a forklift with extended forks (min. 1.85 m long) or other lifting tools (e.g. scissor lift).

 **ATTENTION:**  
The center of gravity of the Cool SmartLift series wall is on the balancing device.

 **WARNING:**  
Severe injuries are possible due to a falling wall.  
Use a lashing strap to secure the wall on the forks of the forklift to avoid falling.

- Carefully lift the Cool SmartLift series wall against the opening of the mounted guide rails and insert the wheels of the trolleys into the rail.



**ATTENTION:**

The center of gravity of the Cool SmartLift series wall is on the balancing device!

- Slide the Cool SmartLift series wall as far into the vehicle as possible so that the Cool SmartLift series wall can not roll out of the **unsecured** rails.

- 
- 
- 
- 
- 

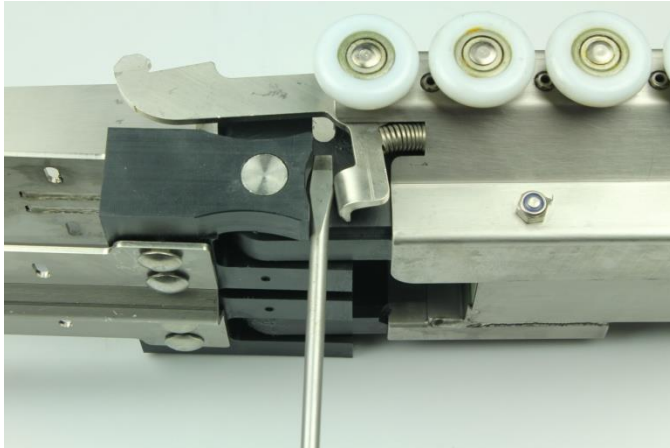

Override the brake with a screwdriver on both sides.

- Push the Cool SmartLift series wall at least so far in the trailer that the locking finger is in a breakhole



**WARNING:**

Severe injuries are possible due to a falling wall.  
Remove the override and assure that the locking finger is in a break hole!



**ATTENTION:**

The wheels are freely movable sideways up to 10mm to compensate for differences in vehicle width.

- Mount the end stops at the bulkhead side of the track. (As is shown on position 8 or 9)

8.



Use the drain hole to mount / attach the end stop.

LoadLok advises to use a M5 x 30 bolt.

9.

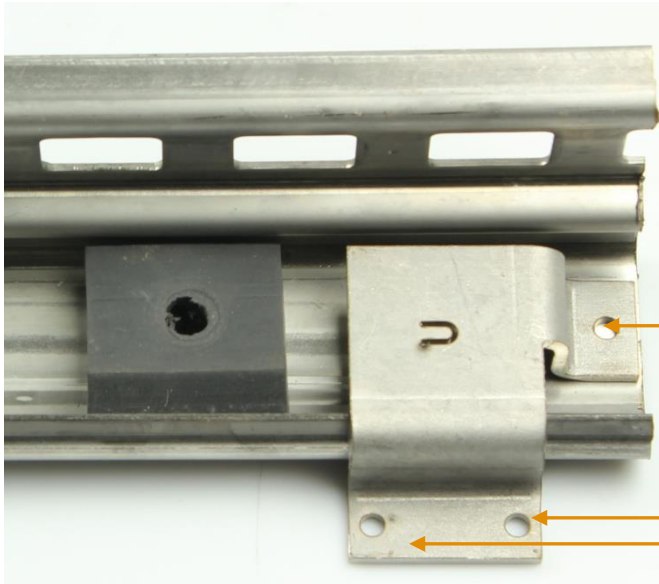

Optional mount the steel stopper as shown in the figure. The hole in the IsoLok Track must be drilled.

In total 3 holes must be drilled!

10.

	<p><b>ATTENTION:</b> Perform step 7 also for the other side of the trailer!</p>
--	---

11.

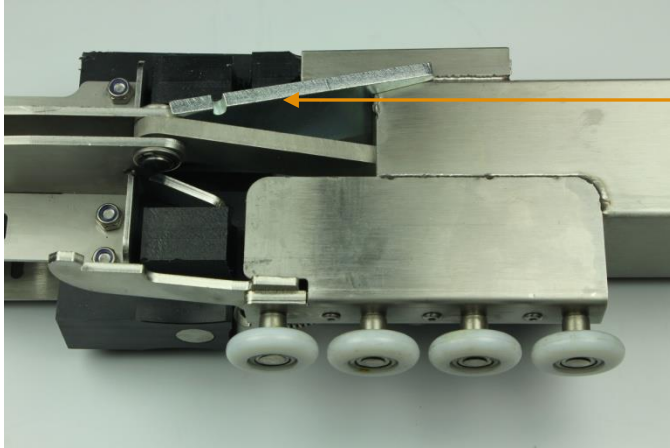

The wall is secured to the balancing device by a transport safety device.

12.



Carefully pull the wall a bit down at an angle of 45° using a belt.

13.

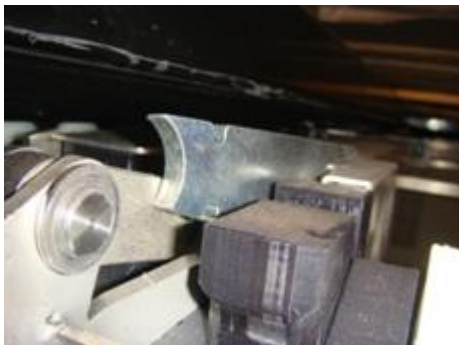

Close the Cool SmartLift series wall a little bit.

Remove the transport safety device from **each** balancer.

14.



Please dispose the transport safety device on environmental friendly manner.

15. Put the Cool SmartLift series wall in horizontal position again.

16.



Carefully pull the wall down at an angle of 45 ° using a belt.

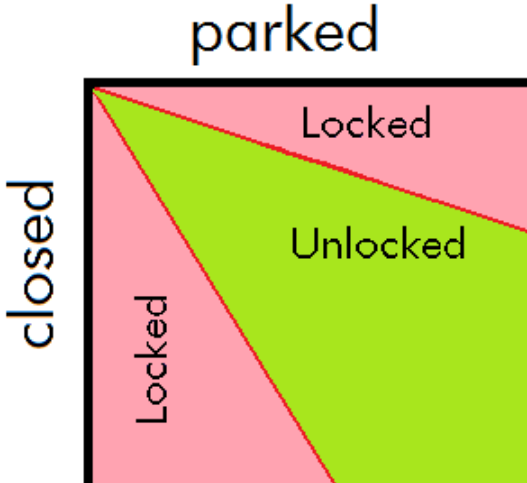

When the Cool SmartLift series wall is in an angle within the green area the Cool SmartLift series wall can be moved freely along the IsoLok Track.

17. Set the Cool SmartLift series wall in vertical position.



## 6 CHECK THE FUNCTIONALITY OF COOL SMARTLIFT SERIES WALL

### 6.1 ADJUST SPRING TENSION

1. Open the Cool SmartLift series wall now to approx. 45°.
2. Move Cool SmartLift series wall with a sweep to the roof.
3. If the Cool SmartLift series wall is not resting in a **parallel** position then:

4.  Remove the plastic cap on the back of the balancing device.

5.  The bolt which holds the spring is visible.  
The spring tension is at its minimum when the door is delivered.

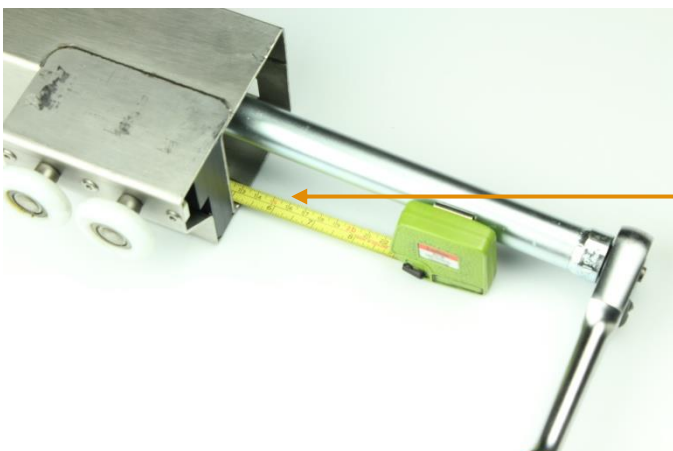
6.  Measure the depth of each balancer.



7.



Use an extended tube wrench (24 mm).

This tool is available at Loadlok



WARNING:

Do **not** use an electric or pneumatic tool!

8. Maximum of 10 mm per side.



ATTENTION:

When the nuts are tightened too far, the mechanism may be damaged!

9. Check if the Cool SmartLift series wall does go smoothly when opening.

If the Cool SmartLift series wall "bangs" to the roof the tension is too tight. Loosen the bolts a bit.

10. Repeat steps 6 to 9, until the Cool SmartLift series wall opens smoothly.

11. Attach the plastic cap at the rear of the balancing device on both sides.

## 6.2 CHECK THE BREAK FUNCTIONALITY

1.

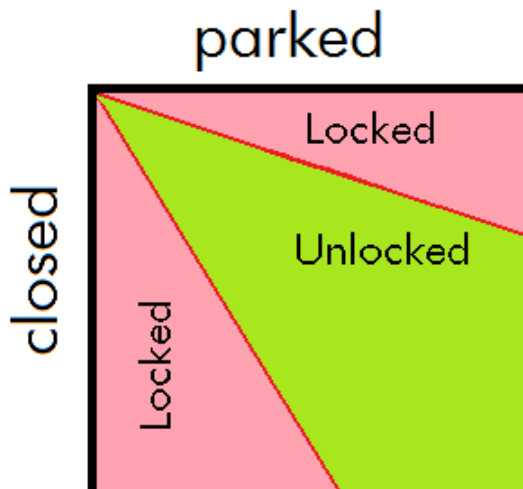

This picture shows the side view of the working area of the Cool SmartLift series wall.

The green colour shows the area in where the Cool SmartLift series wall is unlocked and can be moved freely along the guide rails.

The red areas the Cool SmartLift series wall must grasp in its locking. This area is about 20° from the horizontal and the vertical.

2. Lift the Cool SmartLift series wall into such an angle that it is in the area which is coloured red.

3.

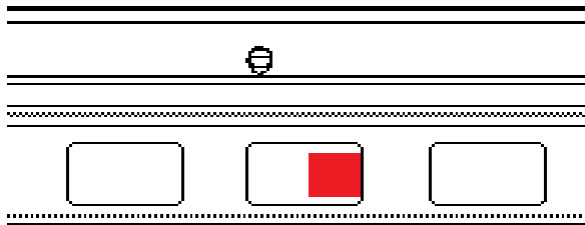

The break locks must be positioned in the middle of the breaking hole (as shown in red).

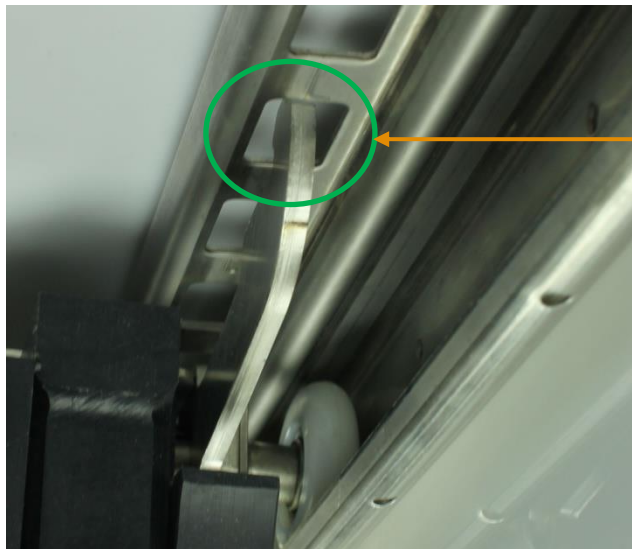

Correct position of the brake in the IsoLok Track

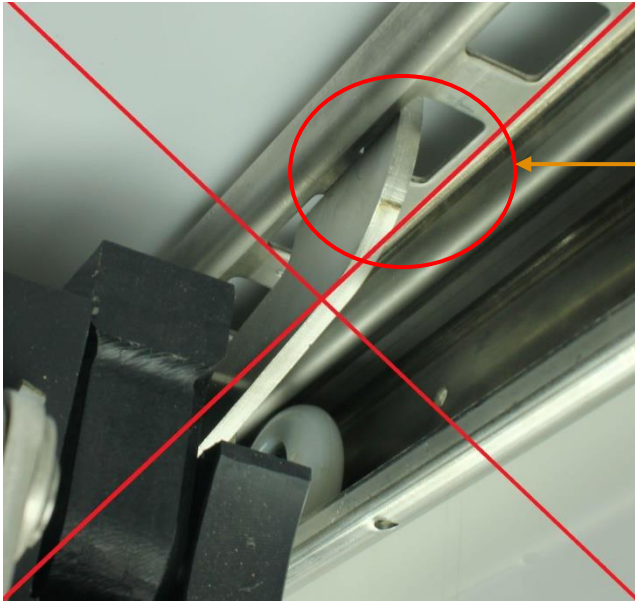

Incorrect position of the brake in the IsoLok Track

4. If this is not the case bend the break lock until it does!

5.

	<p>WARNING: Check both sides!</p>
--	---------------------------------------

	<p>WARNING: If the functionality of the breaking locks cannot be assured:</p> <ul style="list-style-type: none"><li>• Contact Loadlok immediately!</li><li>• Do not deliver vehicle to the public road!</li></ul>
--	---

## 6.3 CONNECTING THE BUILT-IN FAN

### 6.3.1 Without the power supply kit

1.



This slider is mounted by LoadLok, if a fan is built in the Cool SmartLift series wall. The power to the fan is to be supplied via the IsoLok Track.

In this case connect:

- Left side to the power supply, the cable is coloured red.
- Right side to the trailers earth, the cable is coloured black.



WARNING:

In the case of:

- Possibility of short circuit

Use the power supply kit!

Make sure the power supply is secured with a 10A fuse.

### 6.3.2 With the power supply kit



**WARNING:**  
In the case of:

- Possibility of short circuit

Use the power supply kit!



This slider must be mounted on the balancer after the Frigo58 door is set in its place according the instructions in paragraph “Mounting the track”.

In this case connect:

- Left side to the power supply, the cable is coloured red.
- Right side to the trailers earth, the cable is coloured black.



**WARNING:**  
In the case of:

- Possibility of short circuit

Use the power supply kit!

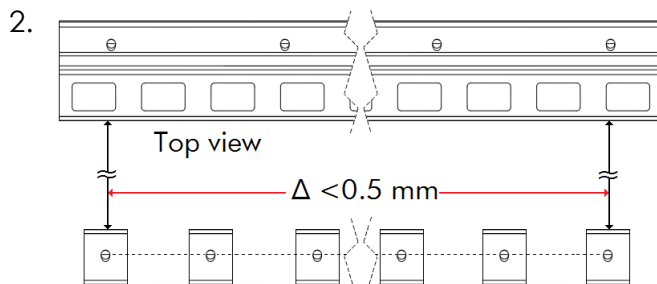

Mount the isolator strips parallel to the IsoLok Track.

3. Every 500 mm an isolator bracket is to be mounted with the tolerance shown in step 2.
4. Slide the aluminum track into the isolator brackets. Make sure that every joint is electrically connected.



**ATTENTION:**  
Check if there is a short circuit before continuing with the installation activities!

5. Connect the power supply to the aluminum rail.

6. Connect the earthing to the right side.
7. Make sure the power supply is secured with a 10A fuse.

**6.4 DOUBLE DECKING SYSTEMS AND COOL SMARTLIFT SERIES WALL**

1.



In order to minimize the height loss, the double deck rail ends within the IsoLok Track.  
This is shown in the figure here.

2.



The wheels on the balancer are extended as show in this figure.  
Loadlok builds these type of balancers when ordering the double decking systems.

3. As both pictures are showing the end result, the built in of the IsoLok Track has to be performed as described the paragraph "Mounting the track".

	<p><b>ATTENTION:</b></p> <p>The notch in the IsoLok Track where the double deck rail has to be mounted should be a minimum of 4 mm (2 mm on each side) wider as the chosen double deck rail.</p>
---	--

	<p><b>WARNING:</b></p> <p>The IsoLok Track loses its stiffness when notches are present. Despite this loss of stiffness, keep the tolerances smaller than 0,5 mm!</p>
---	---

4.

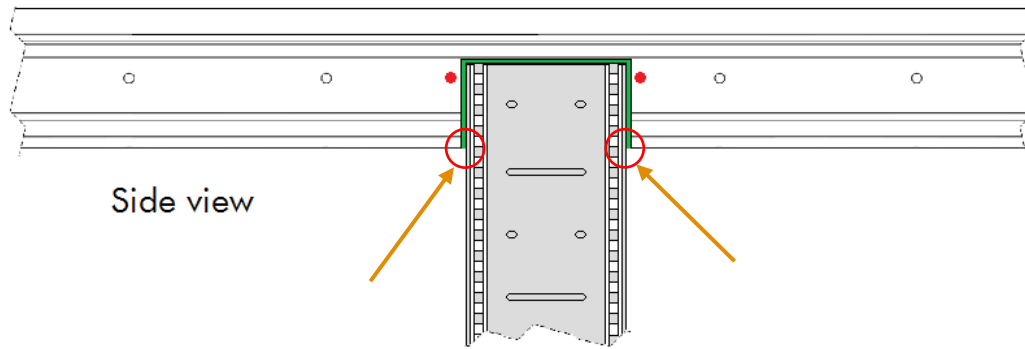

This picture shows a schematic view of how to build the double deck system (vertical rail recessed) into the IsoLok Track (horizontal rail).

The tolerance should be a minimum of 2mm at each side (green colour).

Drill extra mounting holes in the IsoLok Track (red dots), if required.

	<p><b>ATTENTION:</b></p> <p>Loadlok advises to bend the IsoLok Track a bit open, for a better guidance of the balancer wheels!</p> <p>Sections are marked with an red circle in the picture above and in the following picture</p>
--	--

	<p><b>ATTENTION:</b></p> <p>If the double deck rail cannot be recessed then Loadlok advises not to cut out the IsoLok Track!</p>
--	--

5.

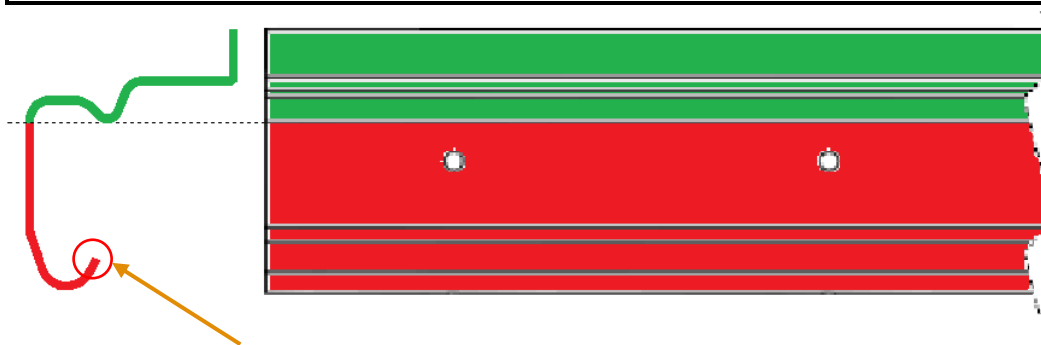

The maximum cutout (intersection) as side and front view

	<p><b>WARNING:</b></p> <p>When creating room for the double deck guidance rails, keep in mind the tolerances for the guidance and locking systems!</p>
--	--



## 7 MAINTENANCE

Maintenance table			
Manifestation of the failure	Possible cause or procedure to detect the failure	Solution	Performed by (unskilled till certified)
Leaking cold PVC-seal has wear	Icing on the sidewall is to be seen	Replace or repair seal of the Cool series wall Manual Lift in the same way as encountered.	Mechanic
The Cool SmartLift series wall is not easily going in to a horizontal or vertical position	Spring tension is not correct	Adjust the spring tension according paragraph "Adjust spring tension"	Mechanic
The breakfingers are not locking in the center of the breaking hole		Adjust the breaking fingers according paragraph "Check the break functionality"	Mechanic

If the Cool SmartLift series wall is inspected on a regular basis on above mentioned inspection points the product lasts a lifetime.

## 8 DOCUMENT INFORMATION

Principal	Contractor	Digital file name
LoadLok Nederland B.V.	Foxiz BV	Mounting Instructions

Remarks, corrections or suggestions are welcomed by the technical department.